

# How Safe are Response Controlled Structures? Limit States of Dampers and Probabilistic Risk

**H. Kit Miyamoto<sup>1&2</sup>, Amir Gilani<sup>1</sup>, Arika Wada<sup>2</sup>**

**Miyamoto International <sup>1</sup>**

**Tokyo Institute of Technology <sup>2</sup>**

# Damper Design

- Moment Frame Members Sized Per Code for Strength
- Dampers Sized to Limit Drift Ratios to Code Limits of 2.0 to 2.5%
- Excellent Performance at DBE & MCE Levels, BUT.....



# Impetus for Research

- We Have Very Few Real Structures With Dampers Exposed to the Large Earthquakes
- Lack of Extensive Data Base
- We Often Change the Codes Earthquake Intensity
  - UBC 97; ASCE 7-05; ASCE 7-10

# Questions to be Answered

- How do we Know that Structures with Dampers Can Perform Well Under Large Event?
- How do we Know Structures with Dampers are Safe when Stiffness of the Frame is Reduced?
- What Happens to the Structure When Damper Limit States are Reached?

# Research Mission

- Identify Viscous Damper Limit States
  - Experimentation & Simulation
- Understand Performance of Damped Structures Subjected to Large Earthquakes
- Create Extensive Data Base and Identify Probabilistic Risk of Steel MRF + Viscous Dampers
  - Incremental Dynamic Analysis (IDA)
- Improve the Code and Practice

# Components of Fluid Viscous Dampers

- Piston Rod: Solid 17-4 PH Stainless Steel,
- Piston Orificing ( $F = C \cdot \text{sgn}(V) \cdot |V|^\alpha$ ).
- Fluid: Silicone Fluid
- Cylinder: Heat-Treated Alloy Steel

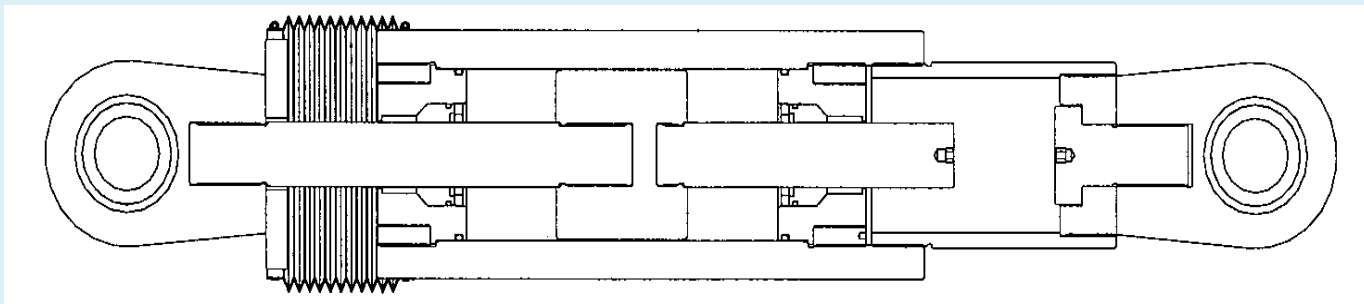

# Viscous Damper Limit States

- Displacement
  - Damper Bottoms Out
  - Converts to Steel Brace
- Force
  - Piston Rod Tension Fractures
  - Driver Brace Buckles
  - Damper Loses Functions

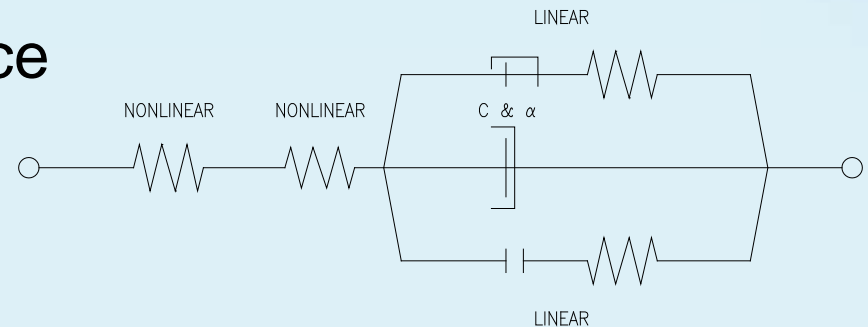

# Tension Limit

- Governed by Piston Undercut
- Short Length
- Fracture Follows Yield Quickly

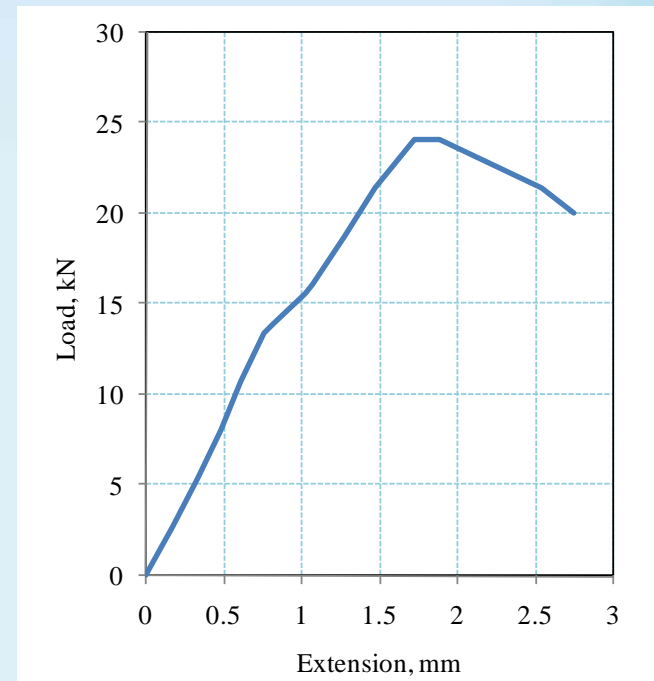
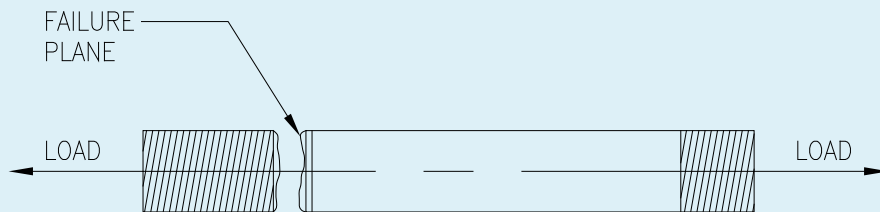

# Compression Limit

- Governed by Driver Brace Buckling
- Piston Rod Has Higher Compressive Capacity

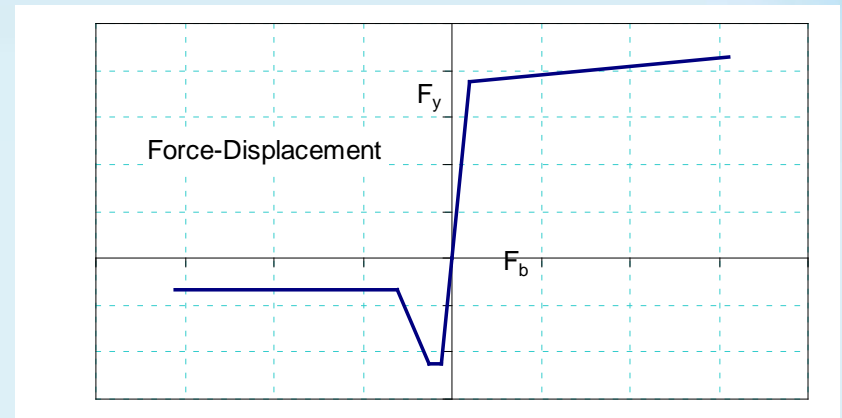

# Stroke Limits

- Piston Head Bottoms Out in Extension or Retraction
- Cylinder Walls
  - Strong and Stiff

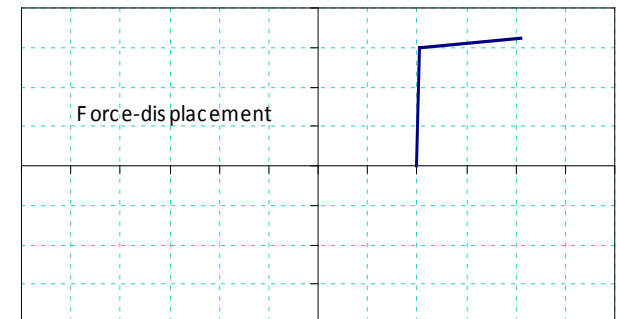
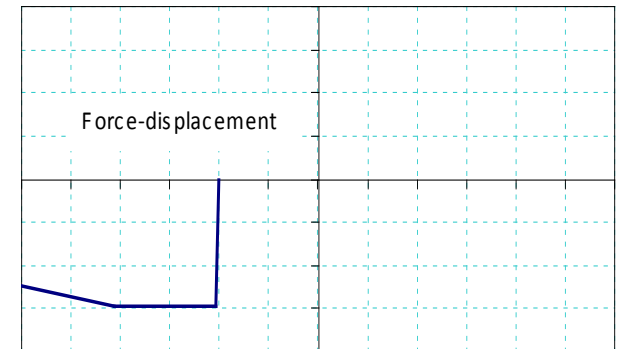

# Sample Damper and Loading

- 660-kN Damper
- Sine Loading with Increasing Amplitude
- Change Models to Activate all Limit States

$$F = 88 \operatorname{sgn}(v) |v|^{0.3}$$

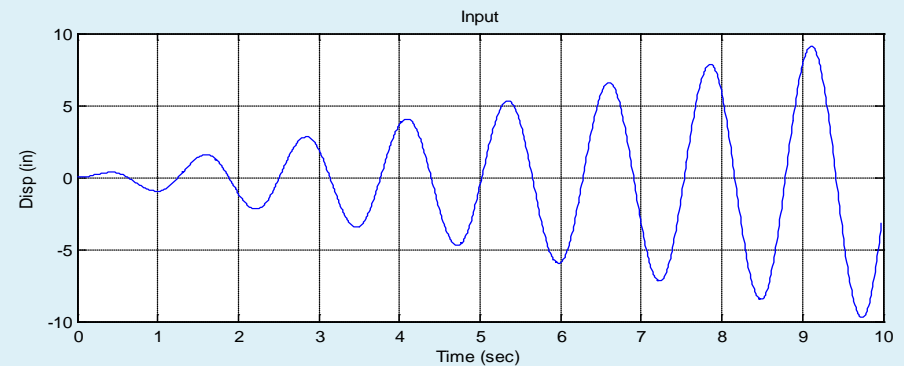

# Force Limit State

- Piston Undercut Yields and Then Fractures

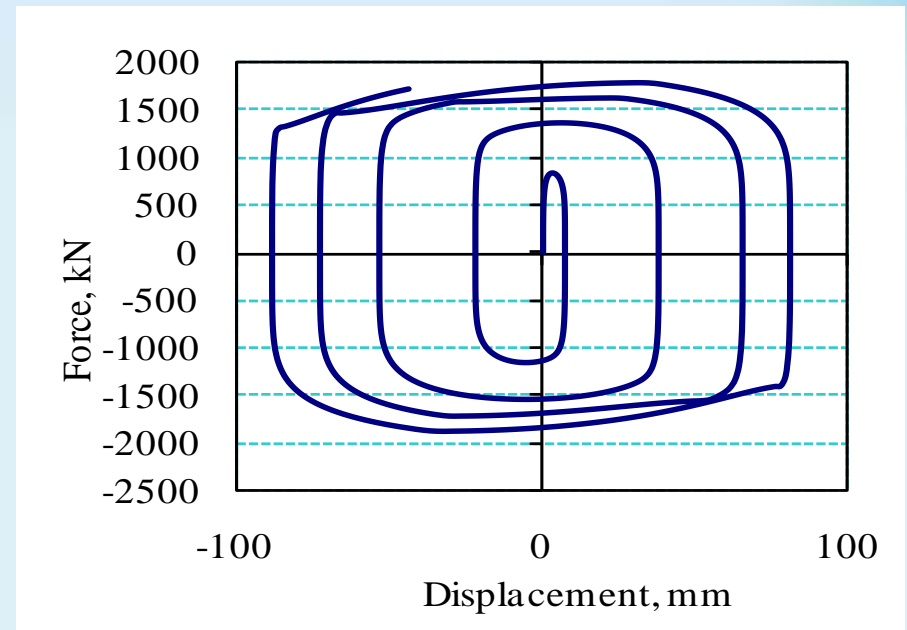

# Displacement Limit State

- Damper Bottoms and Becomes a Stiff Steel Brace

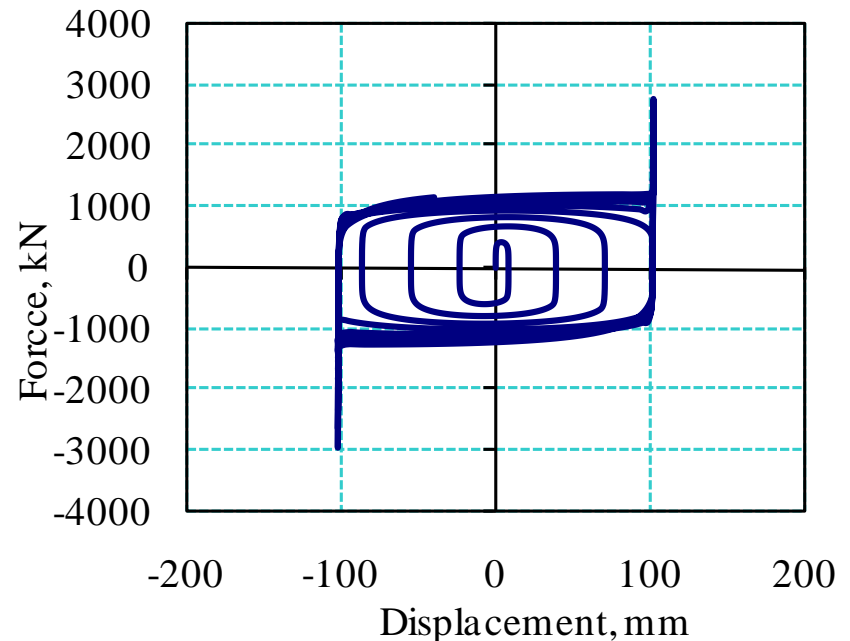

# Compound Limit State

- Displacement Limit
  - Damper Bottoms and Becomes a Stiff Steel Brace
- Force Limit
  - Tensile Fracture or Compressive Buckling

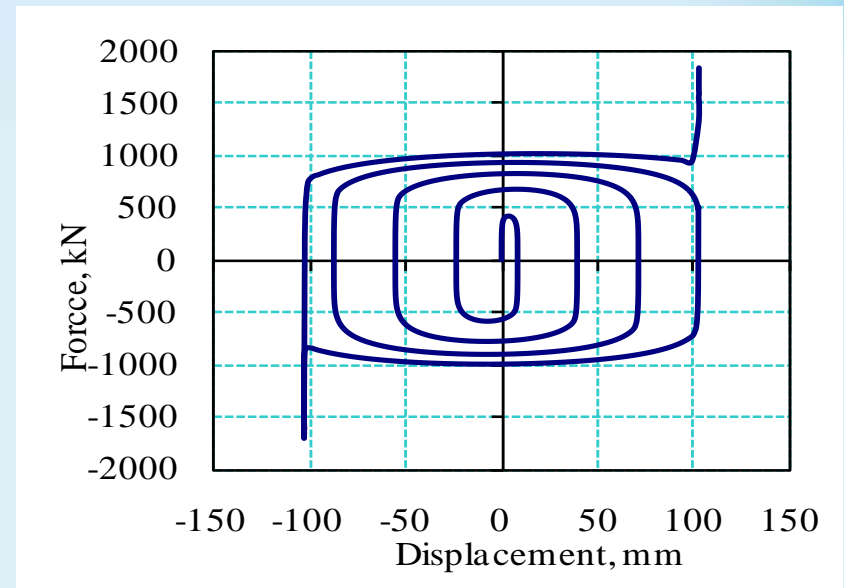

# Correlation with Test Data

- 2000 kN Damper
- Placed Near Stoke Limit in Tension
- Reached Limit States at 300% of Design

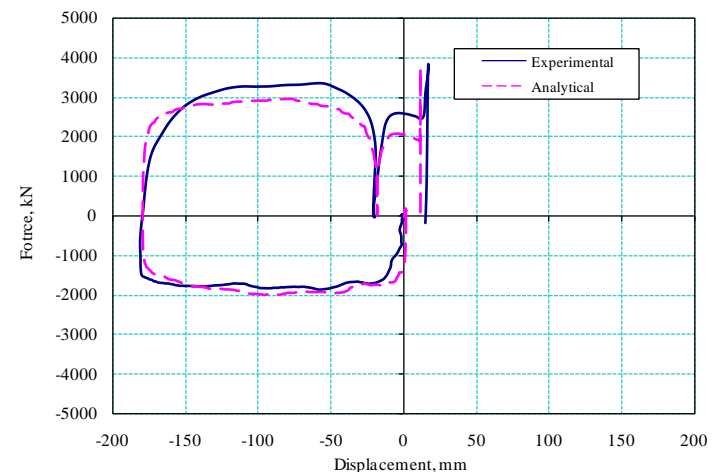
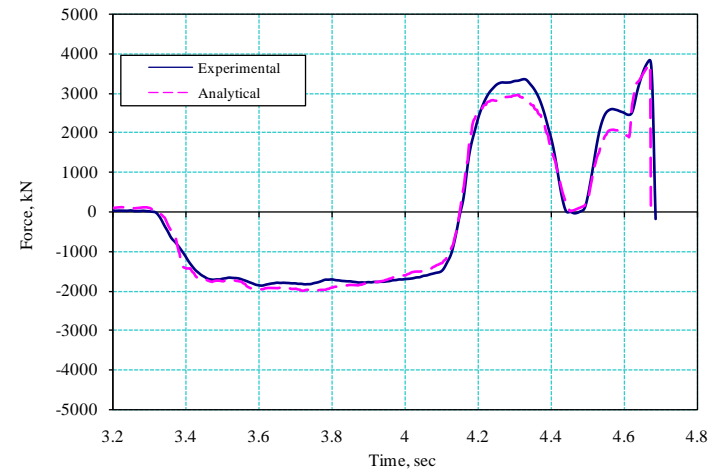
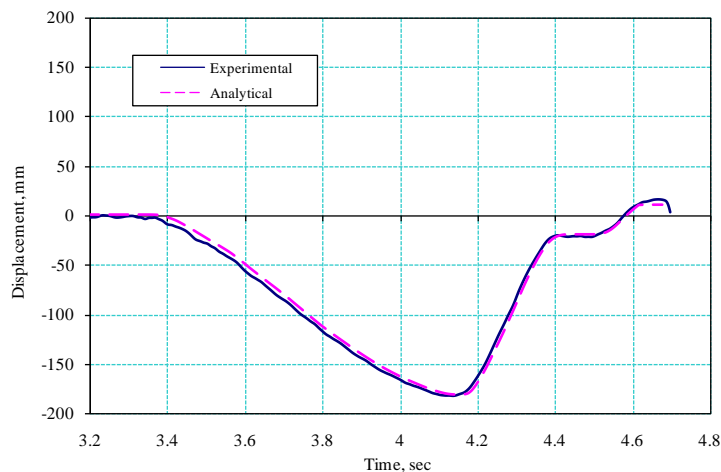

# Archetypes

- 1-story
  - 2-story
  - 5-story
  - 10-story
  - 20-story
  - 30-story
- Sub-Archetypes
    - Column Base Boundary Condition
    - Damper Safety Factor
    - Damper Distribution

# Evaluation Methodology

- PEER NGA (44 Records)
- Detailed Damper Model
- RBS Ductile Connection
- Incremental Dynamic Analysis (IDA)
- OpenSees and SAP

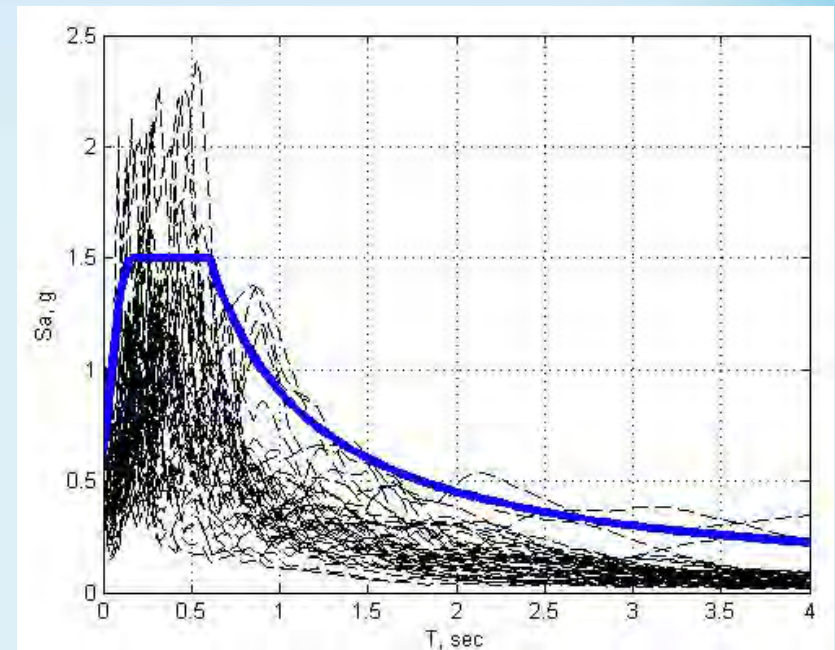

# Beam Plastic Hinge

RBS Hinge  
(Lignos and Krawinkler, 2007)

Hinge Backbone

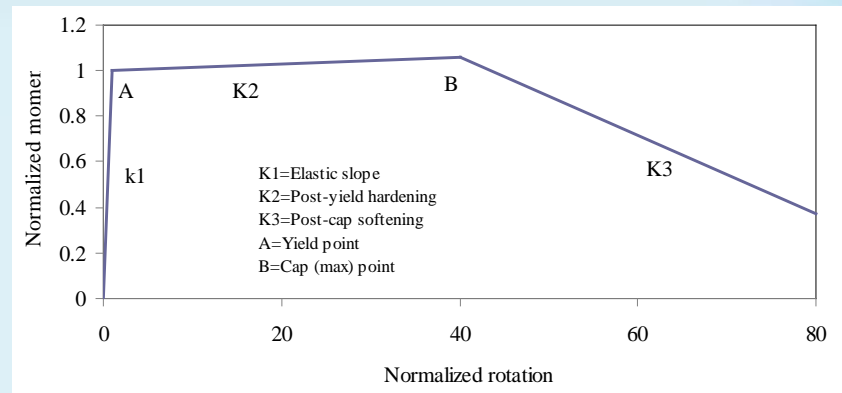
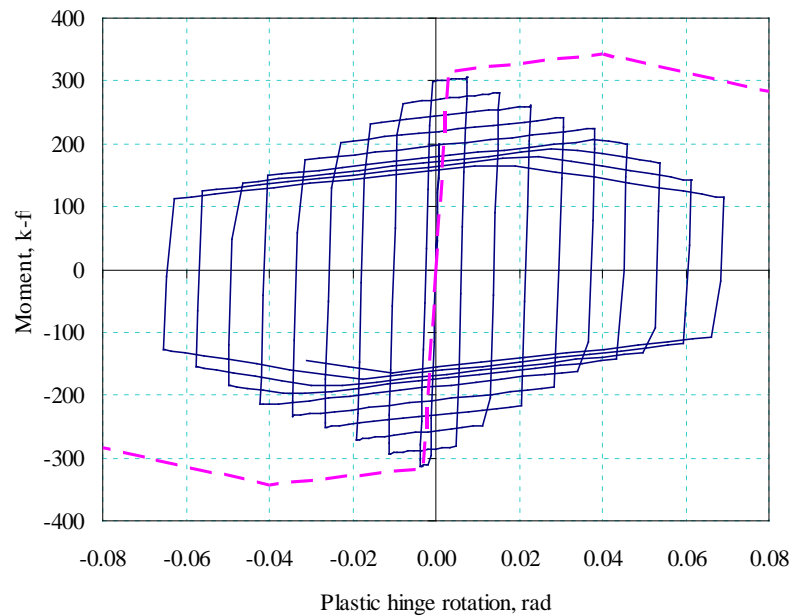

# 1 Story Building

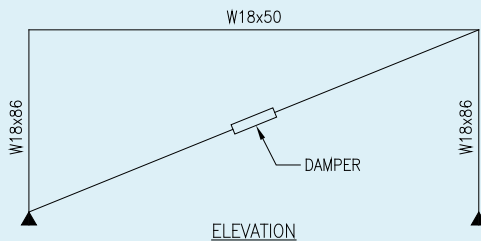
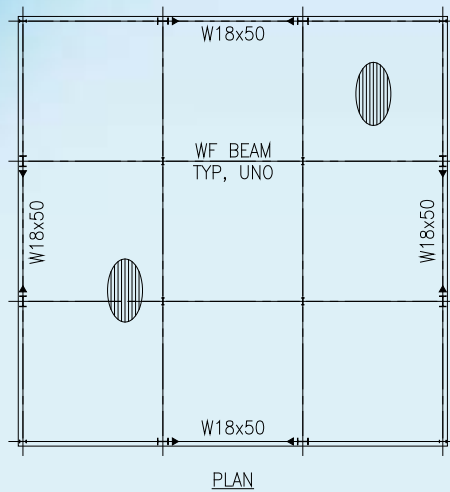

Case	Column Base	Dampers	Safety Factor
O-1	Fixed	No	
O-2	Pinned	Yes	1.0 MCE
O-3	Pinned	Yes	1.3 MCE
O-4	Fixed	Yes	1.0 MCE
O-5	Fixed	Yes	1.3 MCE

# Pushover Curve

- Non-Symmetric and Complex
- Sudden Increase in Stiffness After Bottoming
- Followed by Fracture or Buckling
- Ductile

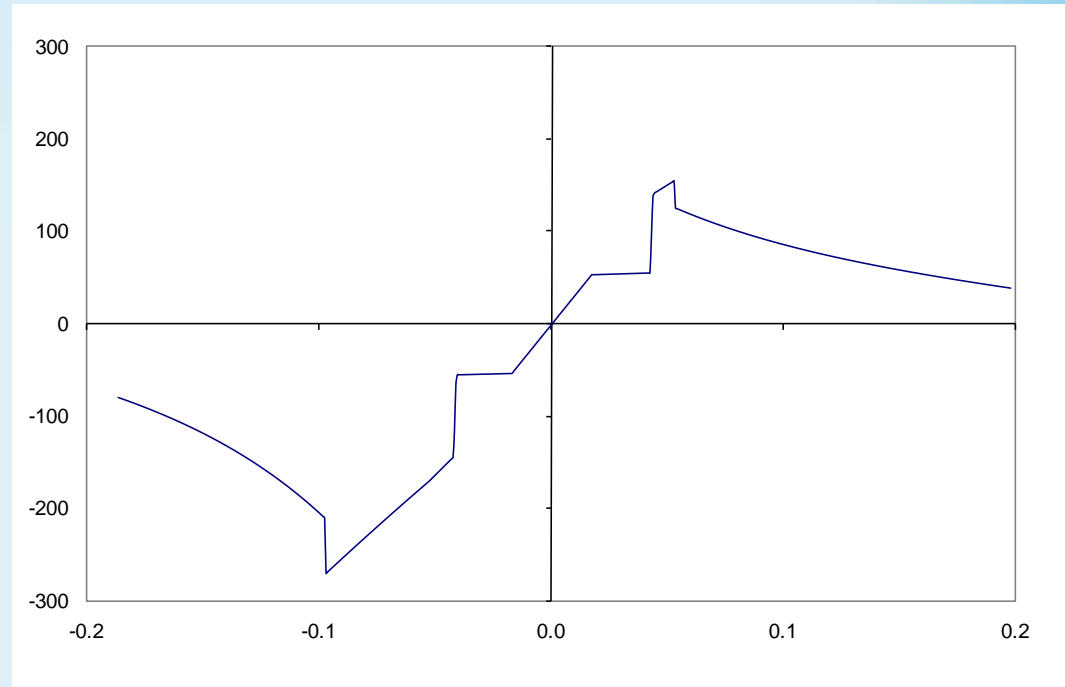

# IDA Curve (O-2)

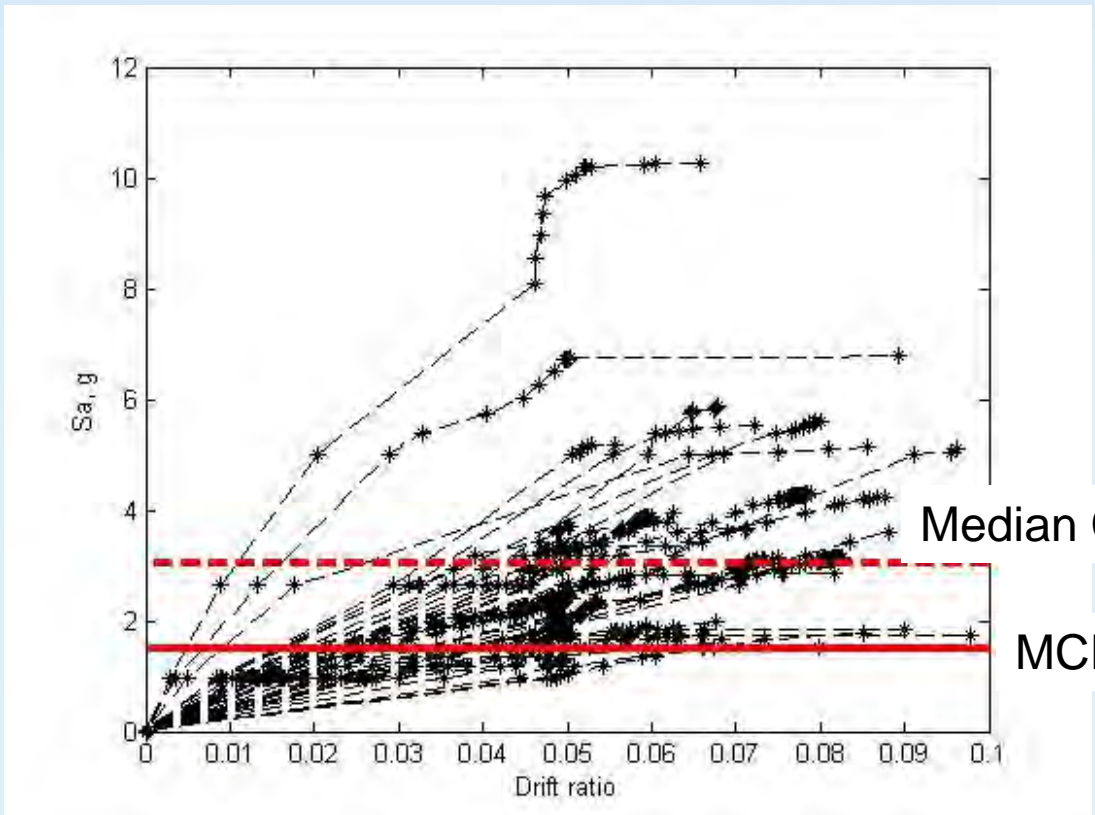

# IDA Curve (O-3)

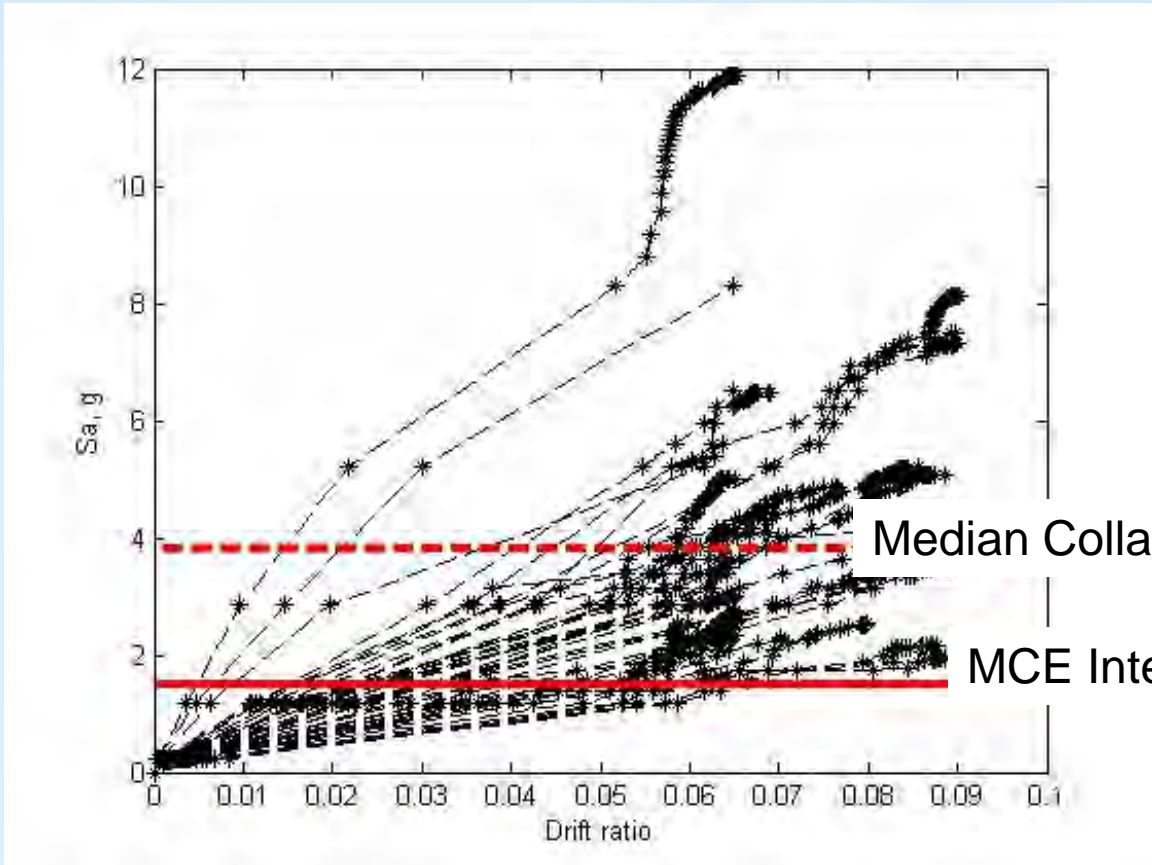

# Fragility Curves, Pinned Base: 1.0 and 1.3 MCE Safety Factor

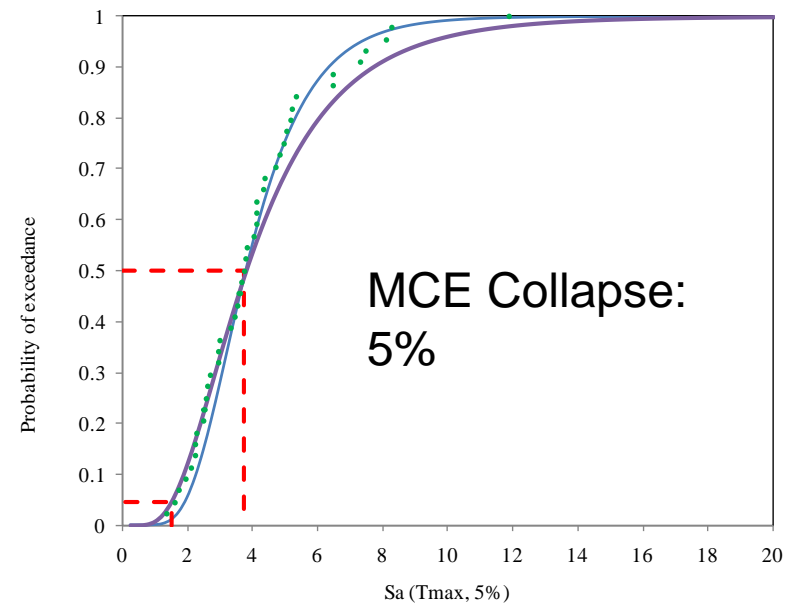
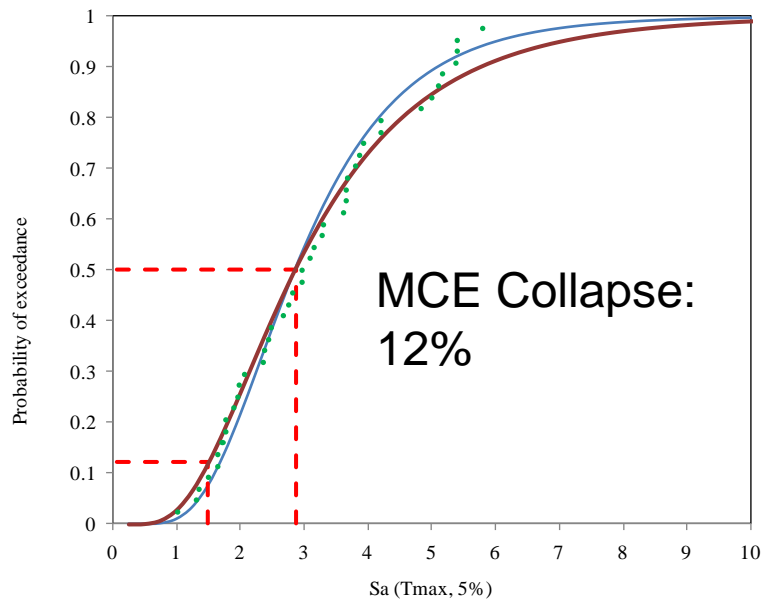

# Results

Case <sup>a</sup>	O-1	O-2	O-3	O-4	O-5
Tmax, sec	0.31	0.31	0.31	0.31	0.31
T1, sec	0.47	1.13	1.13	0.47	0.47
SCT, g	4.42	3.03	3.80	6.26	6.36
$\mu$ c	8.00	8.00	8.00	8.00	8.00
SMT, g	1.5	1.50	1.50	1.50	1.50
CMR	3.46	2.02	2.54	4.17	4.24
SSF	1.34	1.34	1.34	1.34	1.34
ACMR	4.63	2.70	3.39	5.58	5.67

# Two-story archetypes

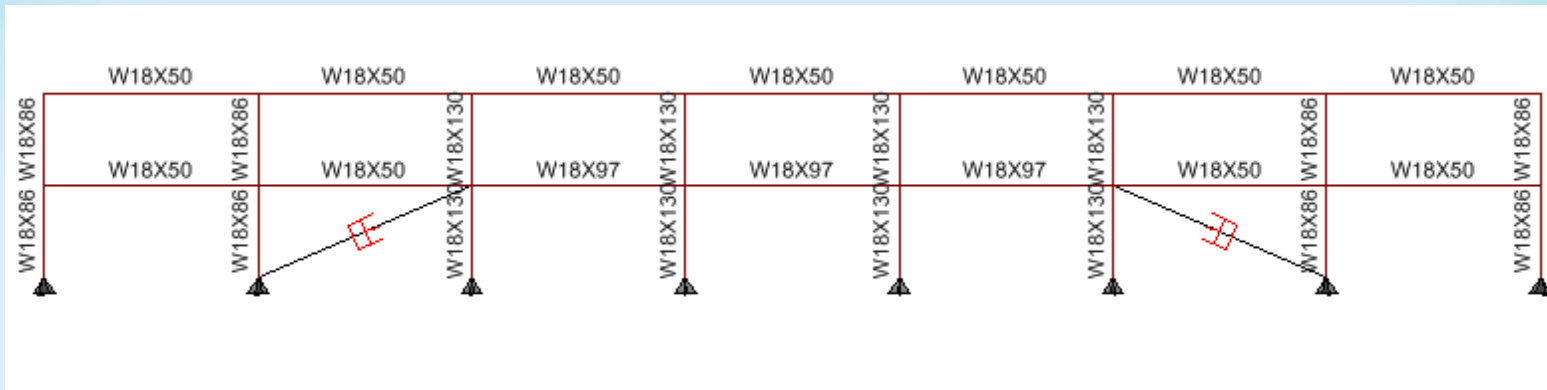

Pinned based frame

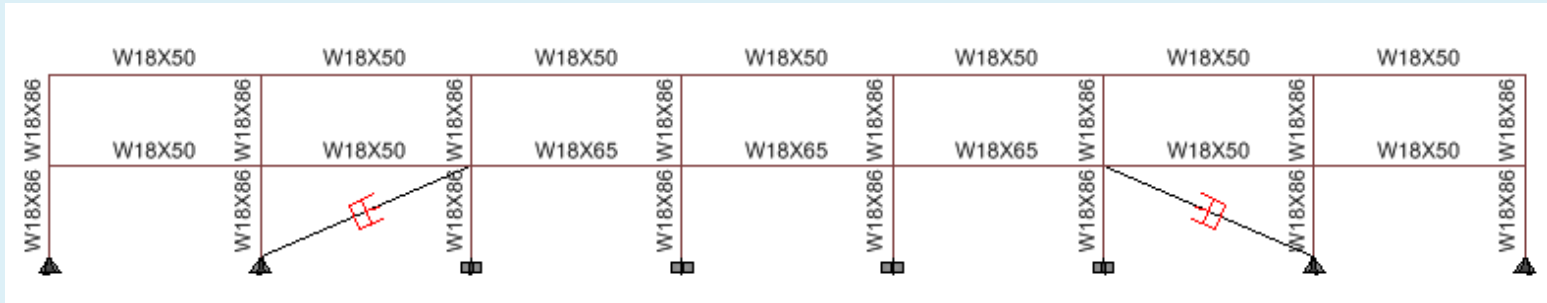

Fixed base frame

# Pushover Curve (A-1)

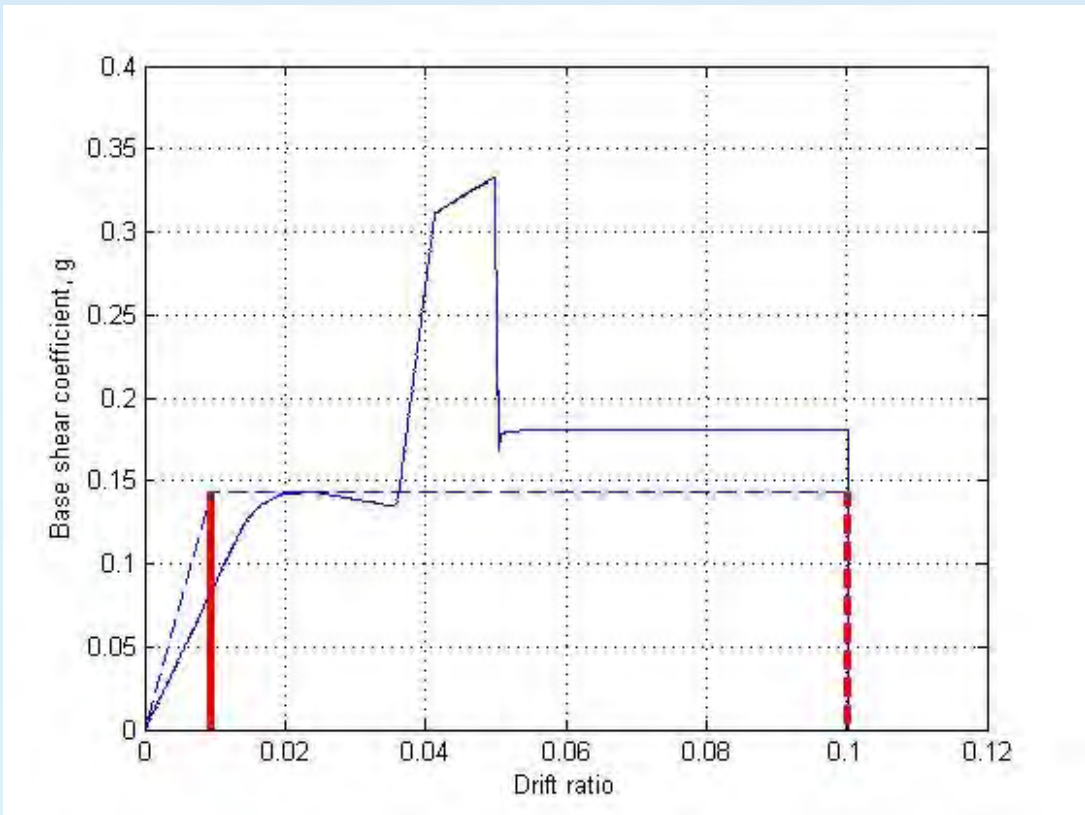

# IDA Curve (A-1)

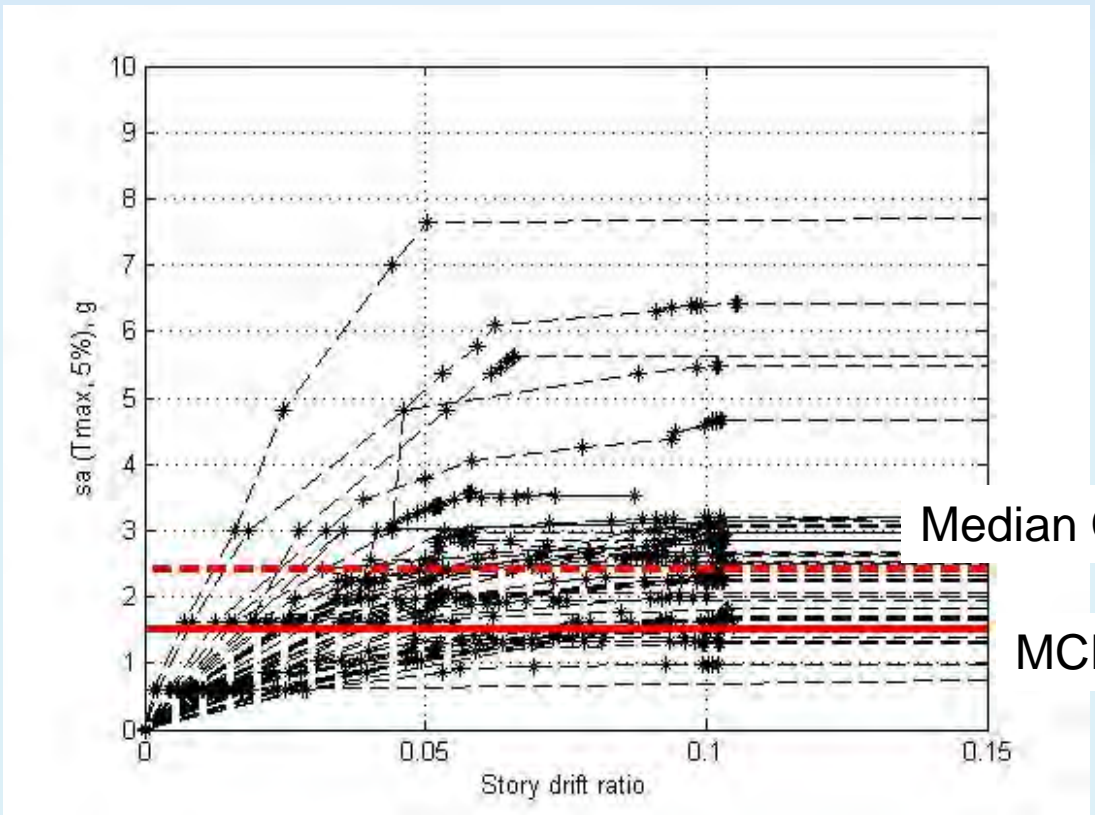

Median Collapse Intensity

MCE Intensity

# Fragility Plot (A-1)

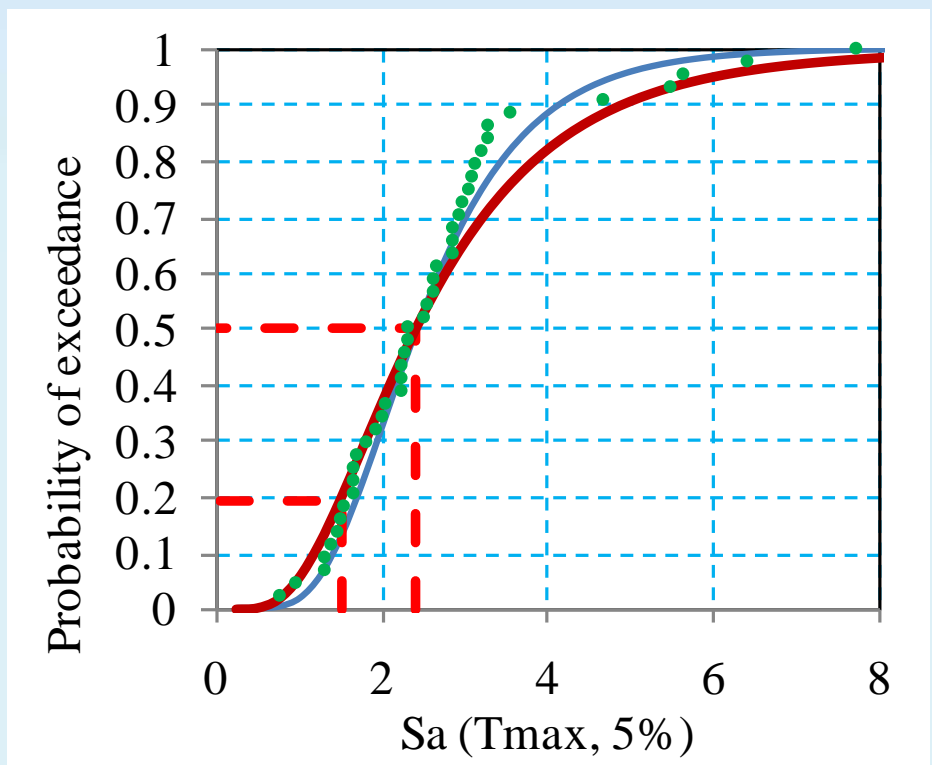

# Results

- All 4 Archetypes Pass

Archetype	Probability of collapse at MCE ( $\beta$ of 0.55)
A-1	18%
A-2	5%
A-3	15%
A-4	7%

# MCE Response (A-1) (Dampers Bottoming)

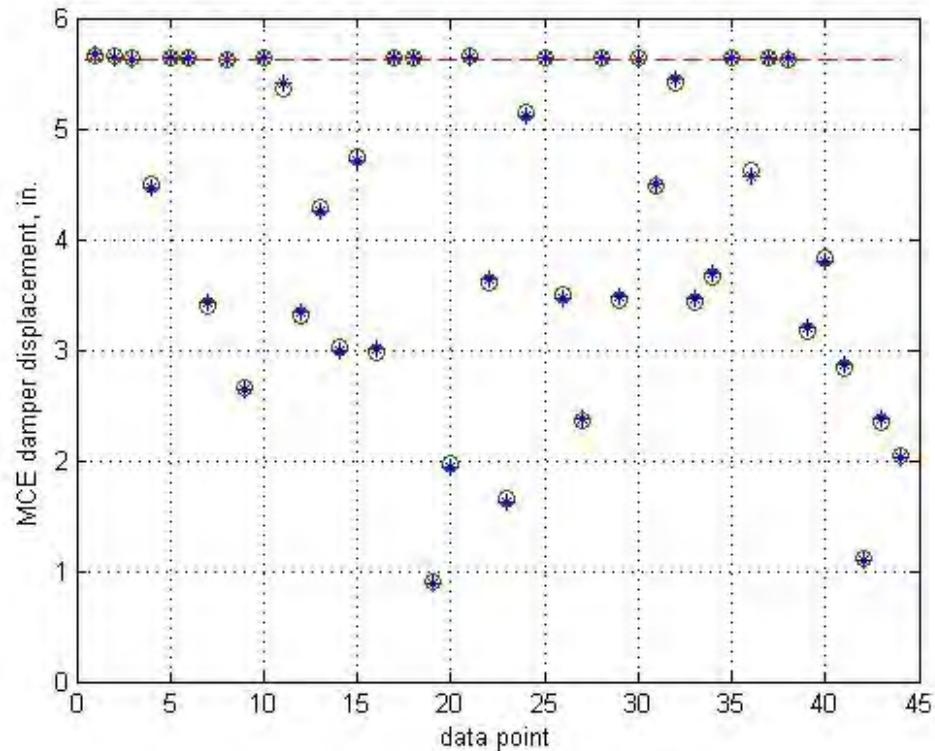

# Damper Stroke Fragility (A-1)

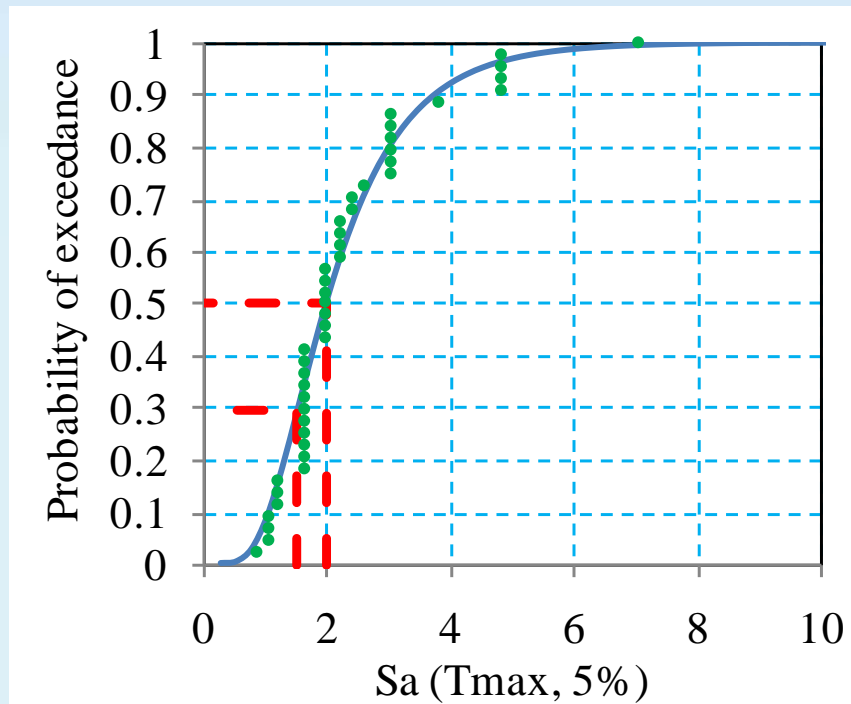

# Damper Responses

Archetype	Median Sa intensity to reach limit		Probability of reaching limit state at MCE	
	Stoke	Force	Stoke	Force
A-1	2.0g	2.3g	29%	14%
A-2	3.4g	3.9g	3%	1%
A-3	1.6g	2.2g	43%	22%
A-4	3.0g	3.4g	10%	7%

# On-going Research

- 5, 10, 20, & 30-Story Archetypes Analysis
- Sub Archetype Adjustments
  - Damper Orientation
  - Damper Safety Factor
  - Driver Brace Capacity
  - Larger First Floor Dampers
  - Affect of Gravity Columns

# Conclusions

- Small Increase in Damper Safety Factor/Quality Provides Significant Reduction in Collapse Probability
- Code Requirement of Dampers Need to be Reassessed

# Acknowledgment

- Taylor Devices, Inc. North Tonawanda, New York
- Amour Steel, Sacramento, California



## MIYAMOTO INTERNATIONAL...

We Make the World a Better Place

miyamoto.